

TRANSFORM LEVEL AND STAIR RAIL DETAILS

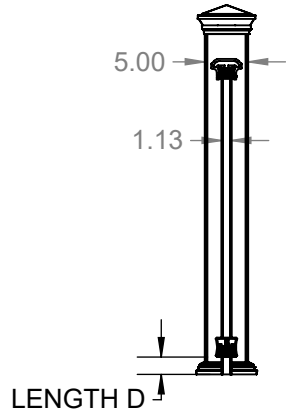

SECTION Z-Z
SCALE 1 : 22

NOTE:
 (A) FINISHED RAIL HEIGHT = 36", 42"
 (B) PANEL LENGTH = 71.75", 95.75"
 (C) MAX SPANS = 98.5X36" IRC, 98.5X42" IBC
 (D) BOTTOM SPACE = 2"- 4"

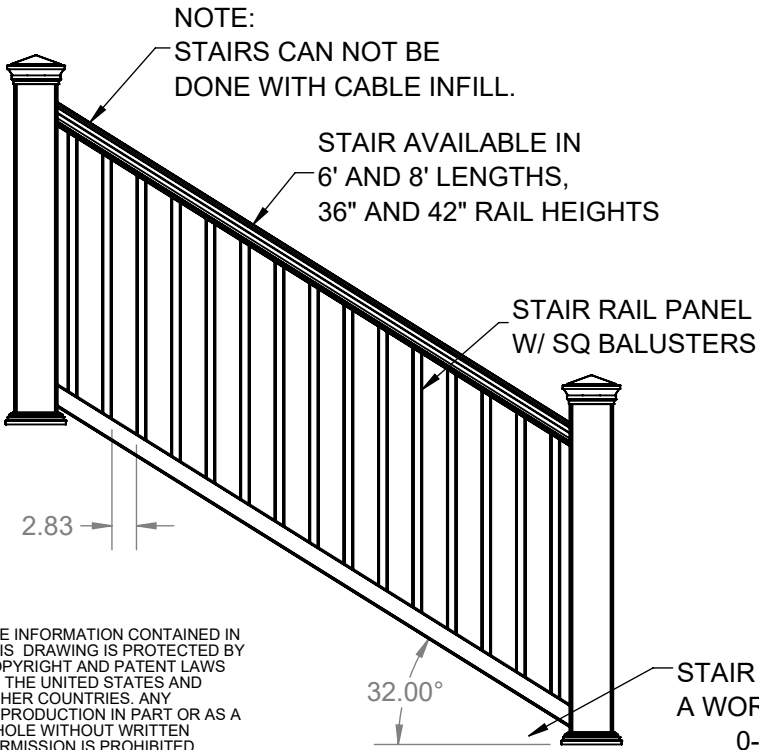
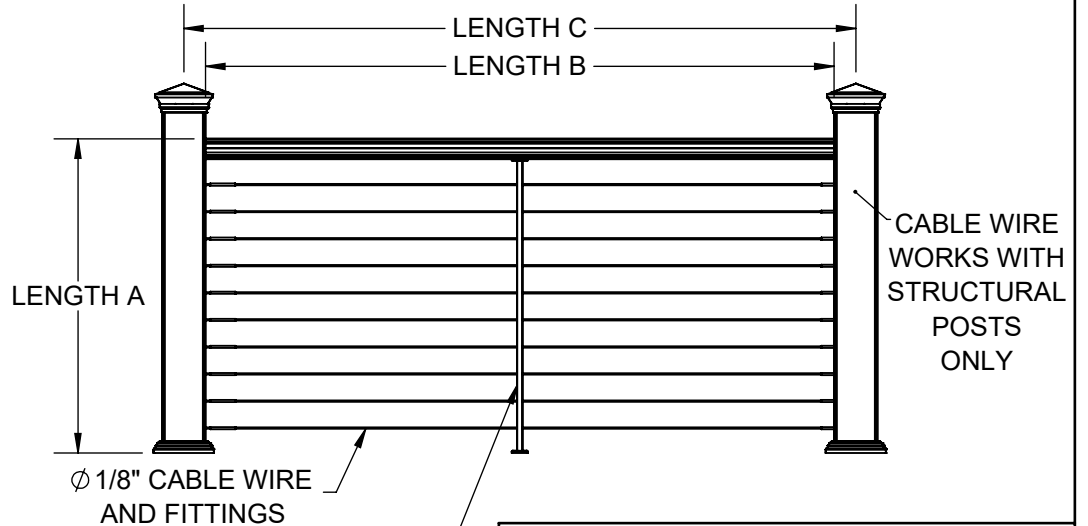
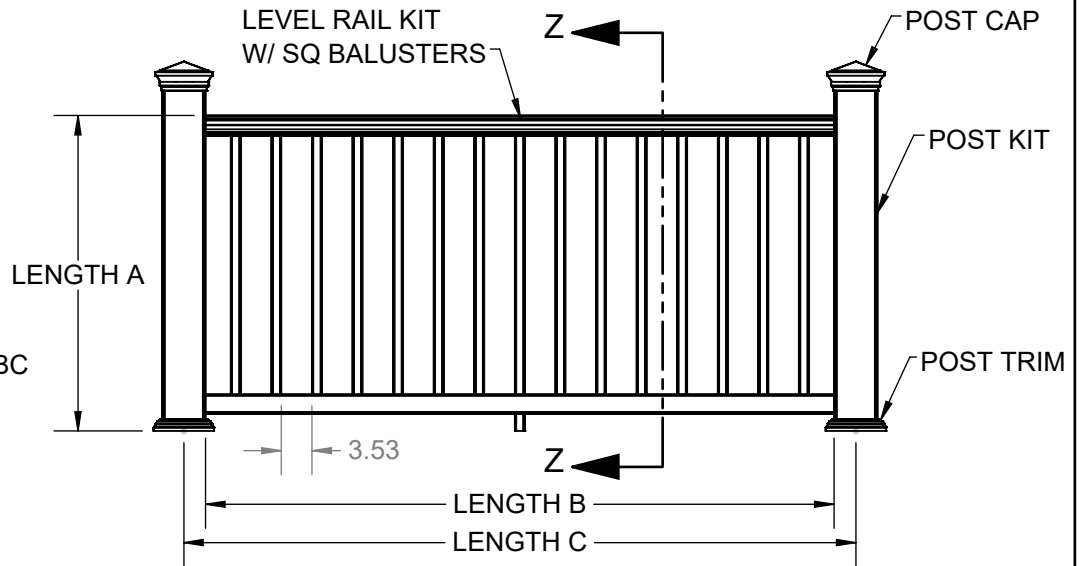

THE INFORMATION CONTAINED IN THIS DRAWING IS PROTECTED BY COPYRIGHT AND PATENT LAWS OF THE UNITED STATES AND OTHER COUNTRIES. ANY REPRODUCTION IN PART OR AS A WHOLE WITHOUT WRITTEN PERMISSION IS PROHIBITED.

		BARRETTE Outdoor Living	
DRAWN: RP	DATE: 04/24/2018	APPROVED:	
DESCRIPTION: TRANSFORM LEVEL AND STAIR RAIL			
SHEET 1 OF 3	REVISION	PART NUMBER	
SCALE 1:22	0	N/A	
WEIGHT: N/A			

TOP AND BOTTOM RAIL

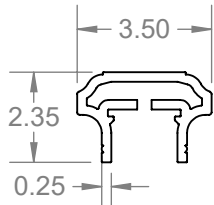

TOP RAIL
ASPIRE

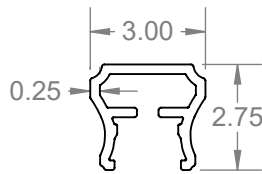

TOP RAIL
EMERGE

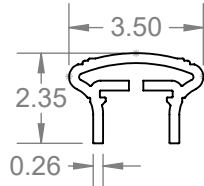

TOP RAIL
PRESENCE

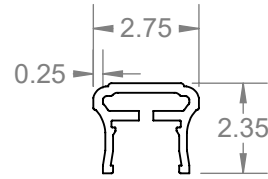

TOP RAIL
GRASPABLE
(STAIR ONLY)

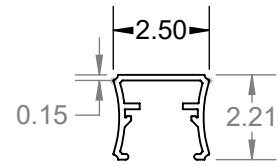

BOTTOM RAIL

POST COMPONENTS

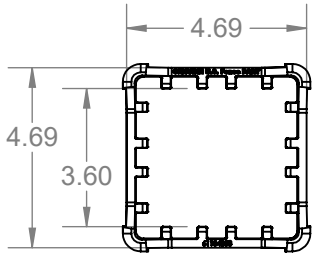

POST SLEEVE INSERT
(INCLUDED W/ SLEEVE)

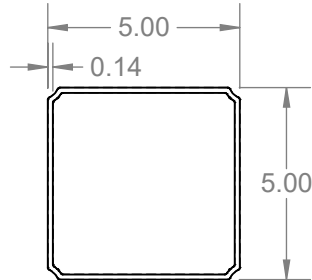

POST SLEEVE

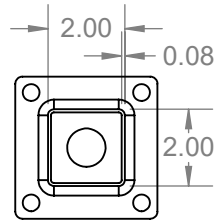

STRUCTURAL POST
(RESIDENTIAL)

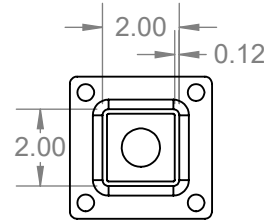

STRUCTURAL POST
(COMMERCIAL)

NOTE: POST SLEEVE INSERT ALIGNS WITH GROOVE ON STRUCTURAL POST INSERT TO WORK WITH 5X5 SLEEVE.

BALUSTERS

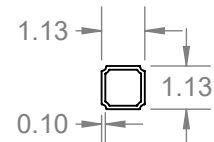

SQ BALUSTER

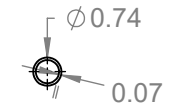

ROUND
BALUSTER



CABLE
WIRE

THE INFORMATION CONTAINED IN THIS DRAWING IS PROTECTED BY COPYRIGHT AND PATENT LAWS OF THE UNITED STATES AND OTHER COUNTRIES. ANY REPRODUCTION IN PART OR AS A WHOLE WITHOUT WRITTEN PERMISSION IS PROHIBITED.

		BARRETTE Outdoor Living	
DRAWN: RP	DATE: 04/24/2018	APPROVED:	
TRANSFORM RAIL PROFILES & INFILL DETAILS			
SHEET 2 OF 3		REVISION	PART NUMBER
SCALE 1:5		0	N/A
WEIGHT: N/A			

TRANSFORM POST AND SURFACE MOUNT DETAILS

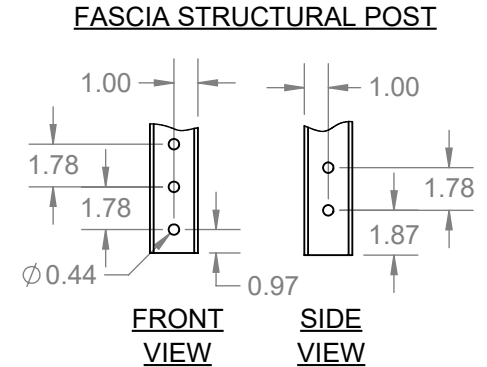
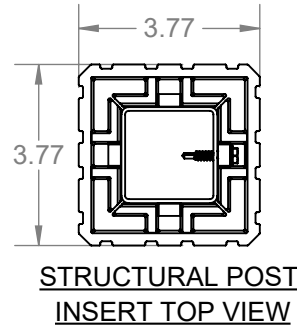
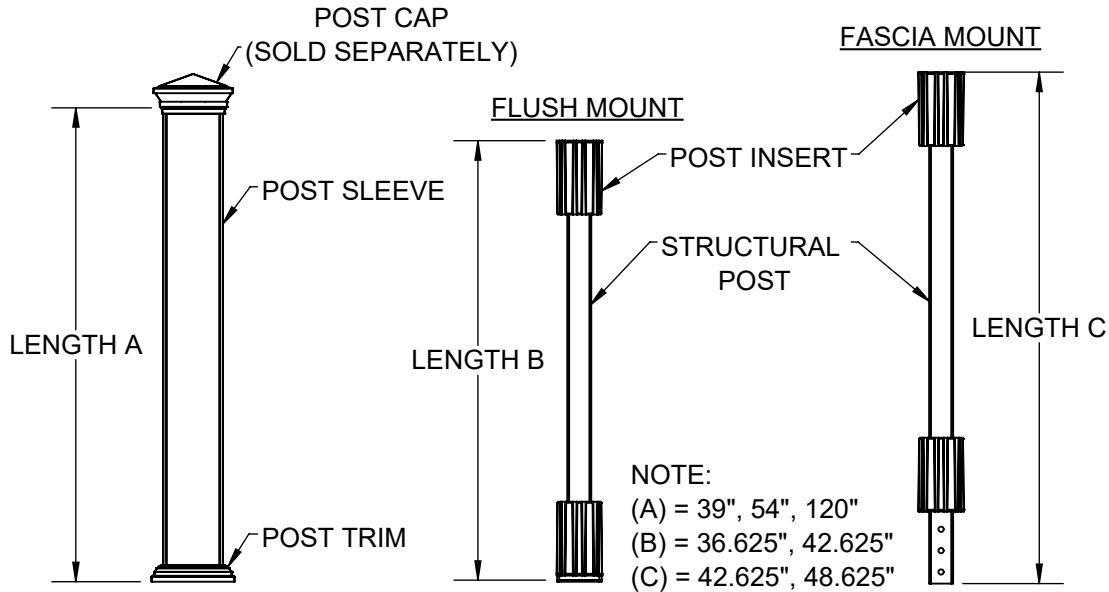

POST BASE CONNECTION INTO CONCRETE WITH WEDGE ANCHORS

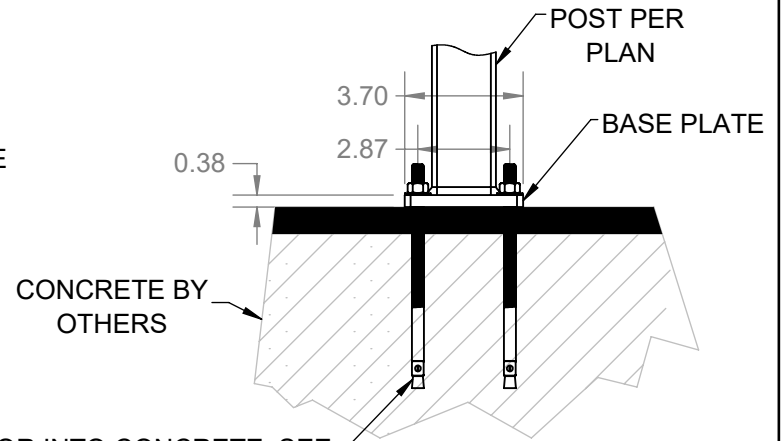

ANCHOR INTO CONCRETE. SEE MANUFACTURER INSTRUCTIONS FOR DETAILS.

POST BASE CONNECTION INTO WOOD WITH THRU BOLT

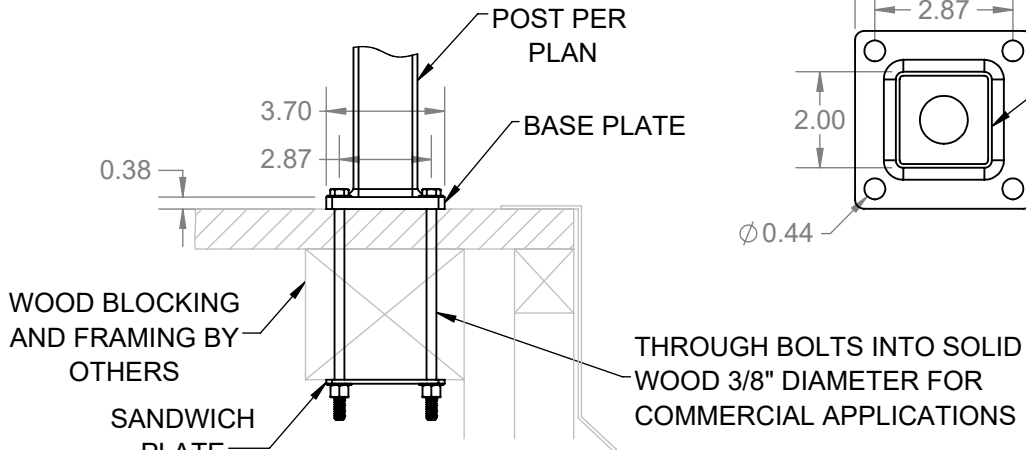

- NOTE:**
1. COMMERCIAL APPLICATIONS ARE ALWAYS BOLTED, USE 3/8" DIAMETER A307 THROUGH BOLTS INTO SOLID WOOD BLOCKING.
 2. WOOD BLOCKING BY OTHERS.
 3. BLOCKING MUST BE DESIGNED TO WITHSTAND PROPER LOADING.

THE INFORMATION CONTAINED IN THIS DRAWING IS PROTECTED BY COPYRIGHT AND PATENT LAWS OF THE UNITED STATES AND OTHER COUNTRIES. ANY REPRODUCTION IN PART OR AS A WHOLE WITHOUT WRITTEN PERMISSION IS PROHIBITED.

		BARRETTE Outdoor Living
DRAWN: RP	DATE: 04/24/2018	APPROVED:
TRANSFORM POST AND SURFACE MOUNT DETAILS		
SHEET 3 OF 3	REVISION	PART NUMBER
SCALE 1:16	0	N/A
WEIGHT: N/A		